

TRADE SECRET –CONFIDENTIAL AND PROPRIETARY  
 EXCLUSIVELY OWNED BY LAPLANTE COMPRESSOR, LTD.,  
 ANY COPYING, USE OR DISCLOSURE WITHOUT THE WRITTEN  
 PERMISSION OF LAPLANTE COMPRESSOR, LTD. IS STRICTLY  
 PROHIBITED. THIS MATERIAL IS PROTECTED UNDER  
 TRADE SECRET AND UNFAIR COMPETITION LAWS. THE  
 EXPRESSION OF THE INFORMATION IS PROTECTED UNDER  
 FEDERAL COPYRIGHT LAWS. VIOLATIONS MAY RESULT IN  
 CIVIL AND CRIMINAL FINES AND PENALTIES.

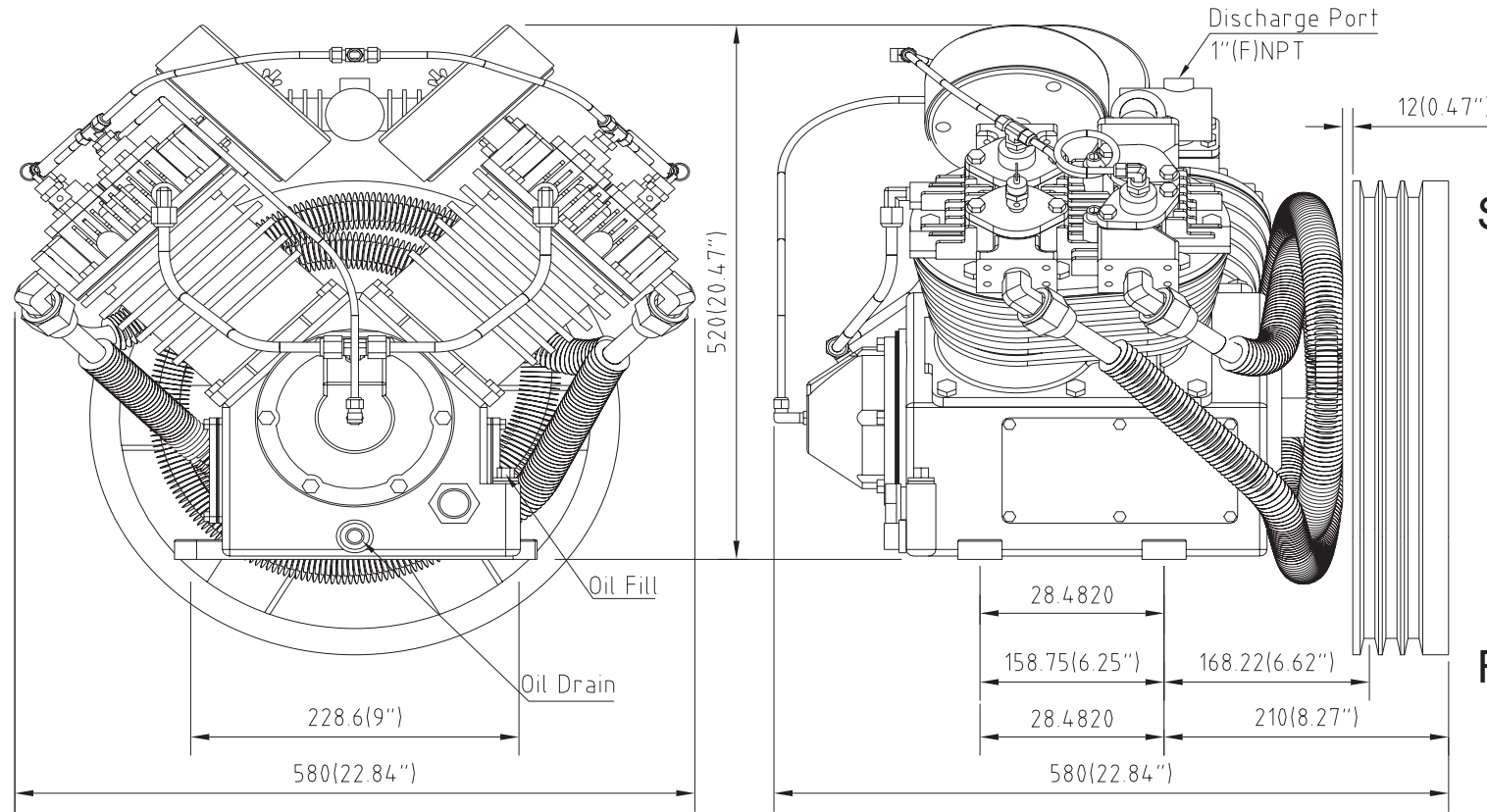

**Specification:**

- Power Range: 6.5~11HP/4.8~8.2Kw
- Maximum Pressure: 175Psi/12Bar
- Cylinders: 4
- Bore of LP: 4.75"/120.65mm
- Bore of HP: 2.5"/63.5mm
- Stroke: 3"/76mm
- RPM: 500~750
- Flywheel Dia./Groove: 18"/457.2mm/3B

**Features:**

- Cast Iron Crankcase
- Cast Iron Cylinder
- Cast Iron Cylinder Head
- Ductile Iron Crankshaft
- Ductile Iron Conn. Rod
- Head Unloader and Centrifugal Unloader
- Cage Needle Bearings Wrist Pin
- Babbitt Bearings Crankshaft
- Taper Main Bearings
- Steel Breather and Brass Sight Glass
- Power Coated Steel Filter Silencer
- Filled with DAB150 Lubricant
- Synthetic Lubricant as Optional

**Standard Package:**

- Single : 1 Pcs,Weight:247LB/112Kg
- Crate : 6 Pcs,Weight:1540LB/700Kg
- 20' Container : 99 Pcs
- 40' Container : 186 Pcs

LP452 Performance (Delivery)

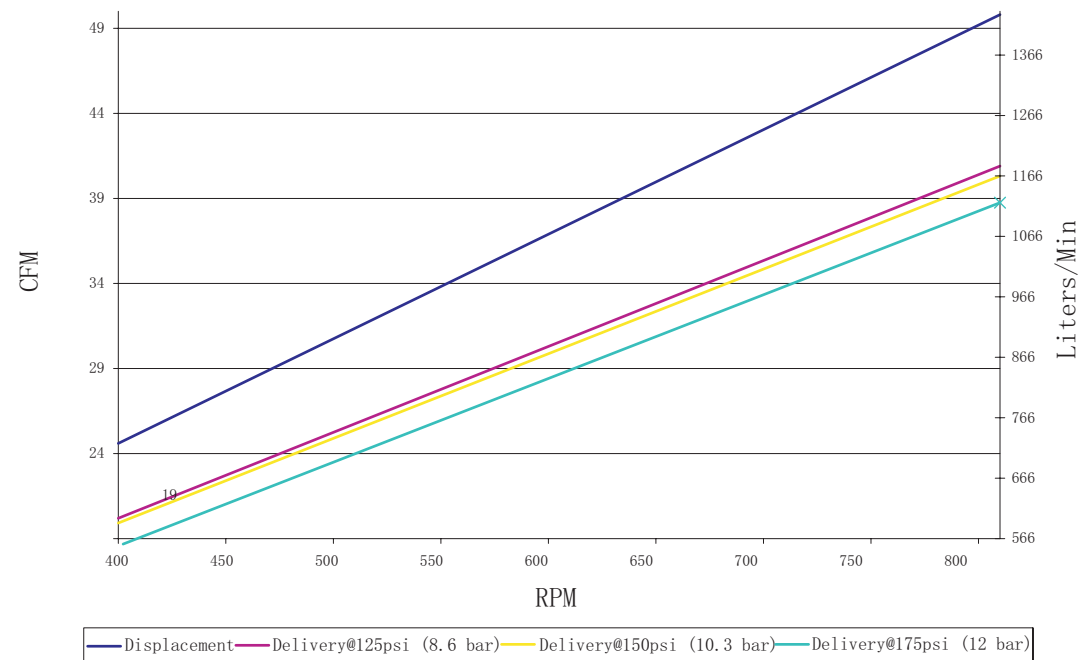

LP452 Performance (Power)

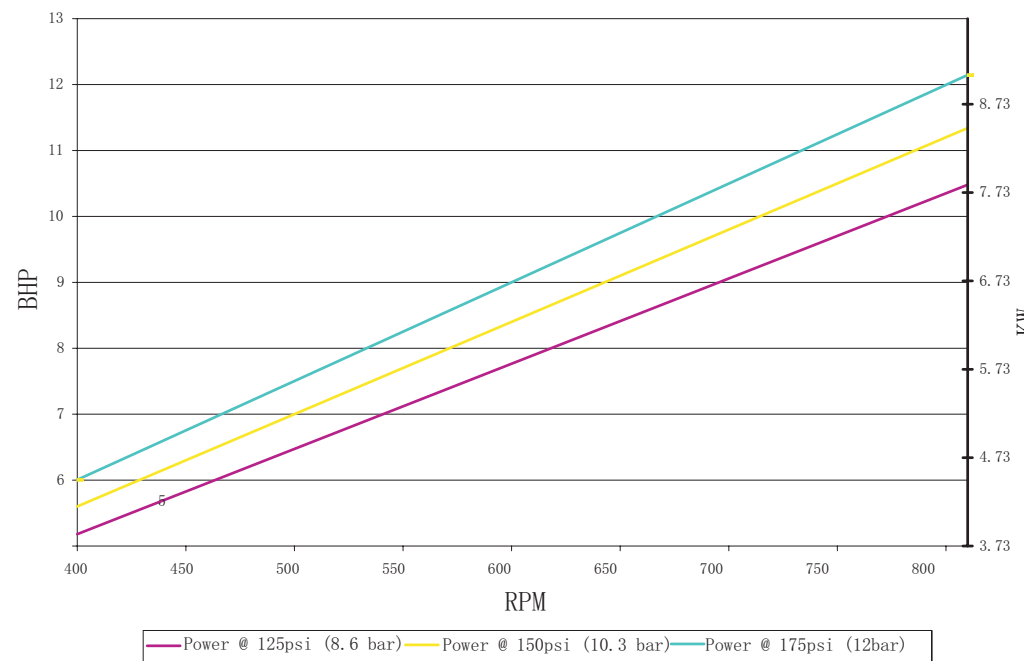

Address:7502 Mesa Road Houston, TX77028  
 Telephone: (713) 635-6331  
 E-mail: sales@Lapante.com  
 Web Site: www.Laplantecompressor.com

TITLE  
**LP452 Specifications**