

TRADE SECRET –CONFIDENTIAL AND PROPRIETARY
 EXCLUSIVELY OWNED BY LAPLANTE COMPRESSOR, LTD.,
 ANY COPYING, USE OR DISCLOSURE WITHOUT THE WRITTEN
 PERMISSION OF LAPLANTE COMPRESSOR, LTD. IS STRICTLY
 PROHIBITED. THIS MATERIAL IS PROTECTED UNDER
 TRADE SECRET AND UNFAIR COMPETITION LAWS. THE
 EXPRESSION OF THE INFORMATION IS PROTECTED UNDER
 FEDERAL COPYRIGHT LAWS. VIOLATIONS MAY RESULT IN
 CIVIL AND CRIMINAL FINES AND PENALTIES.

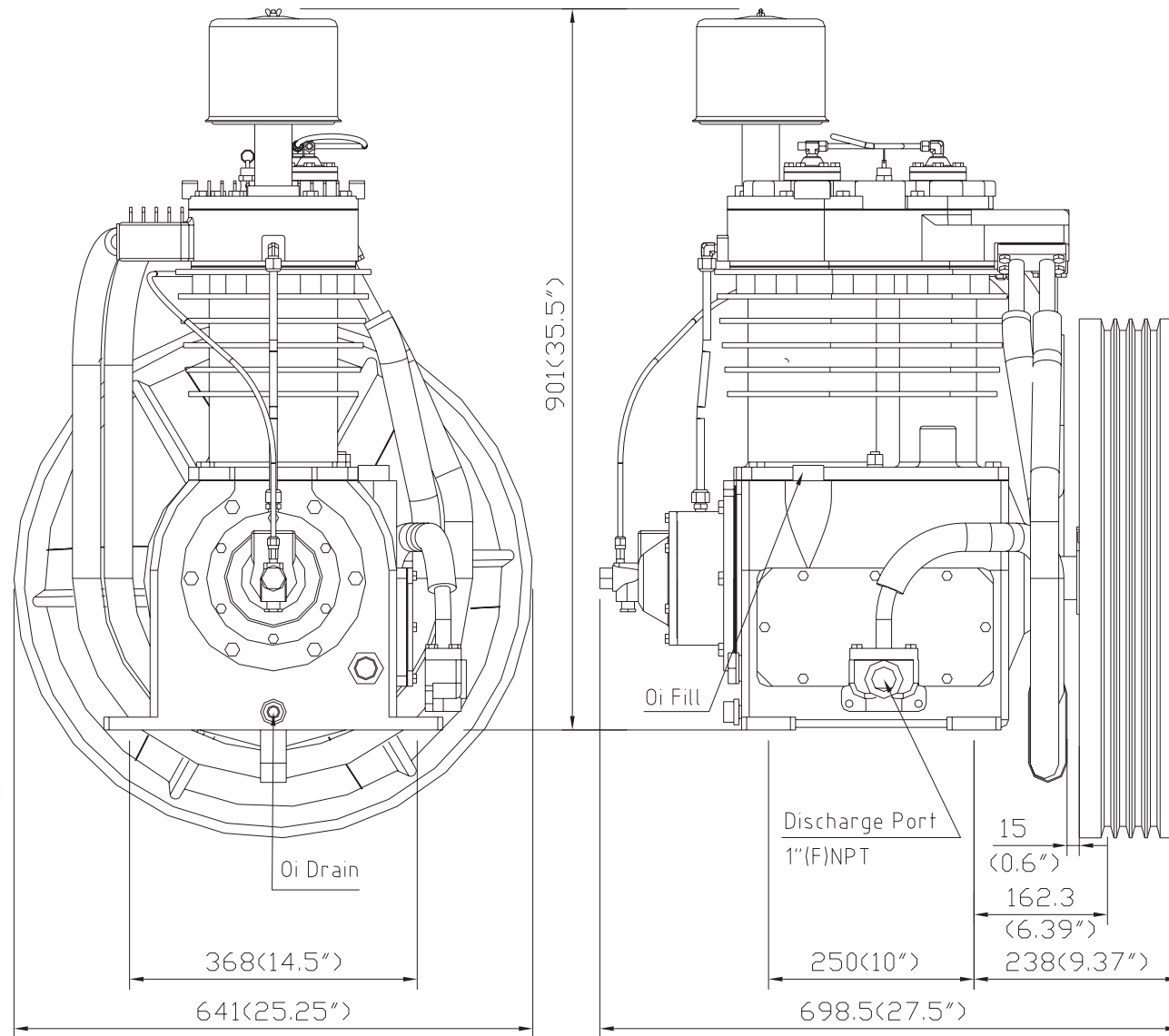
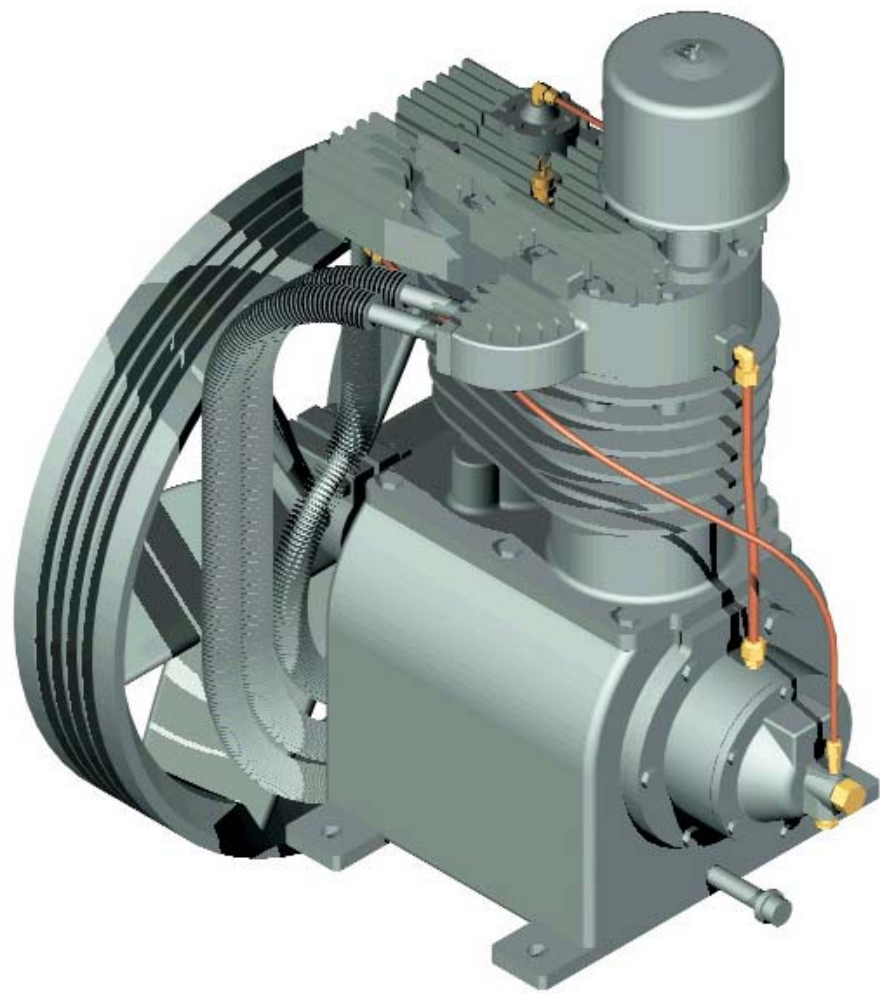

Specification:

- Power Range: 10~12HP/7.46~8.9Kw
- Maximum Pressure: 175Psi/12Bar
- Cylinders: 2
- Bore of LP: 5.5"/140mm
- Bore of HP: 3"/76.2mm
- Stroke: 5"/127mm
- RPM: 650~800
- Flywheel Dia./Groove: 25.25"/641mm/3B

Features:

- Cast Iron Crankcase
- Cast Iron Cylinder
- Cast Iron Cylinder Head
- Ductile Iron Crankshaft
- Ductile Iron Conn. Rod
- Head Unloader and Centrifugal Unloader
- Cage Needle Bearings Wrist Pin
- Babbitt Bearings Crankshaft
- Taper Main Bearings
- Steel Breather and Brass Sight Glass
- Power Coated Steel Filter Silencer
- Filled with DAB150 Lubricant
- Synthetic Lubricant as Optional

Standard Package:

- Single : 1 Pcs,Weight:507LB/230Kg
- Crate : 3 Pcs,Weight:1587LB/720Kg
- 20' Container : 42 Pcs
- 40' Container : 96 Pcs

LP352 Performance (Delivery)

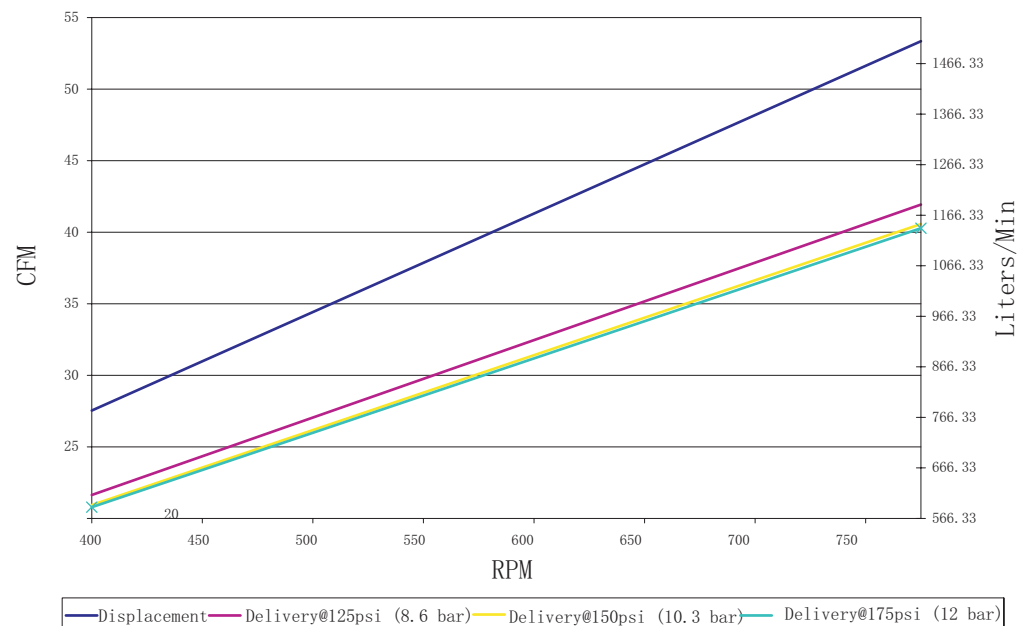

LP352 Performance (Power)

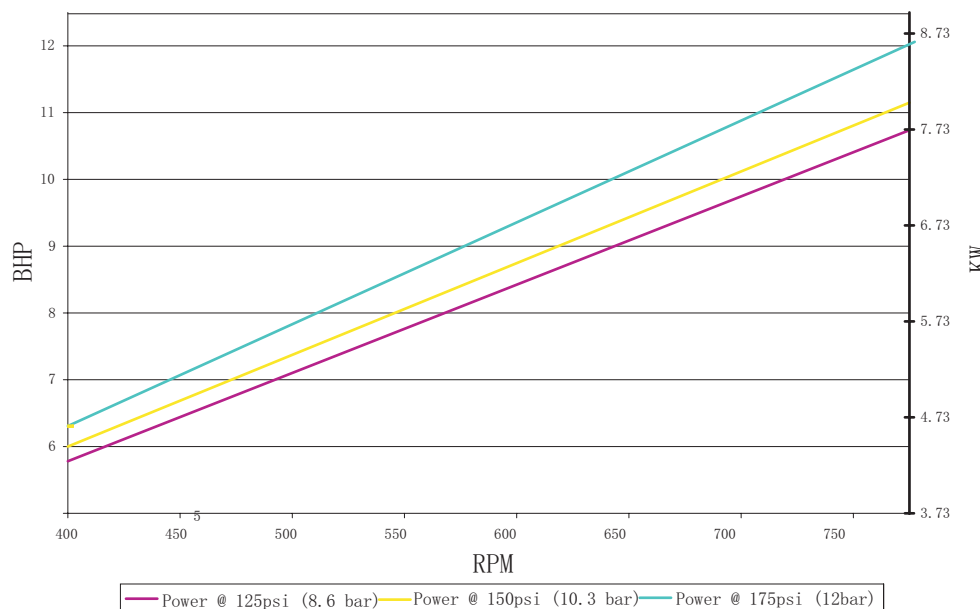

Address:7502 Mesa Road Houston, TX77028
 Telephone: (713) 635-6331
 E-mail: sales@Lapante.com
 Web Site: www.Laplantecompressor.com

TITLE

LP352 Specifications